

5.5 SIDES OF RIGHT TRIANGLES (THE PYTHAGOREAN THEOREM)

CHECK YOUR UNDERSTANDING

PART A

1) Identify the hypotenuse for each of the following right triangles.

a)

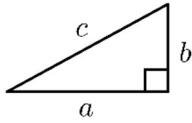

b)

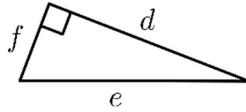

c)

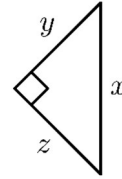

d)

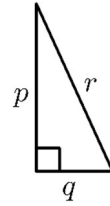

2) Determine the area of the indicated square in each of the following diagrams.

a)

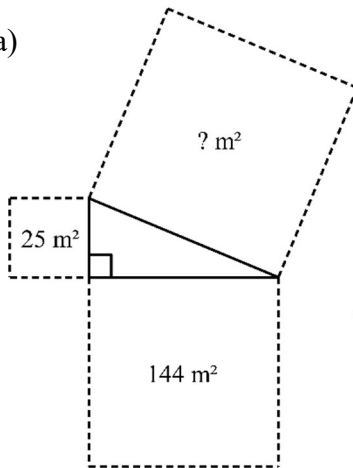

b)

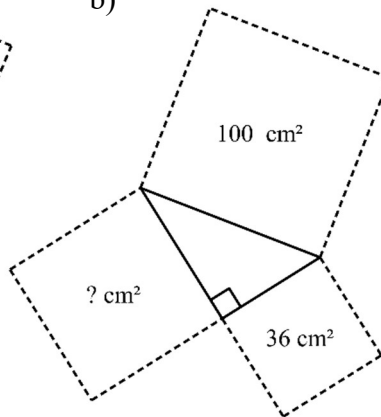

3) For each of the following, use the given areas to determine side lengths a , b and c .

a)

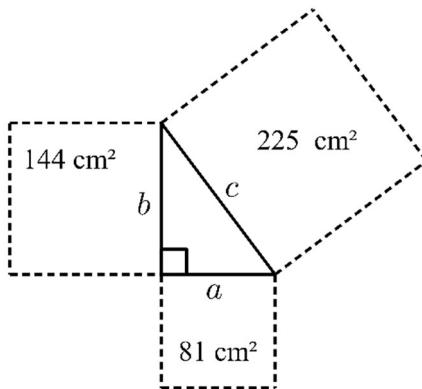

b)

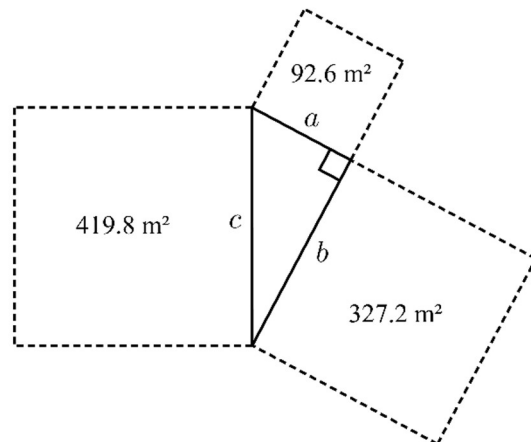

4) Use the given areas to determine the side length x in each of the following diagrams.

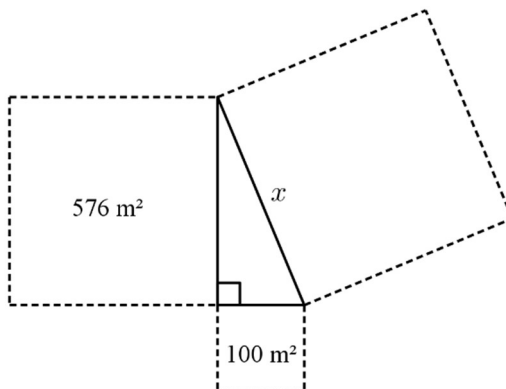

PART B

5) Determine the unknown side length in each triangle.

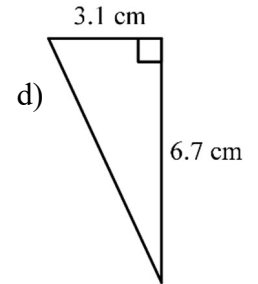
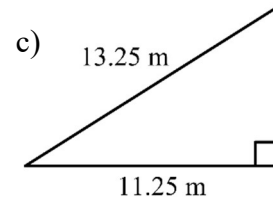
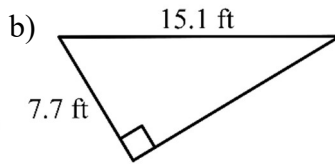
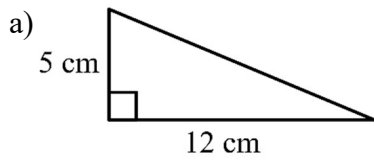

6) Determine the area and perimeter of the triangle shown on the right.

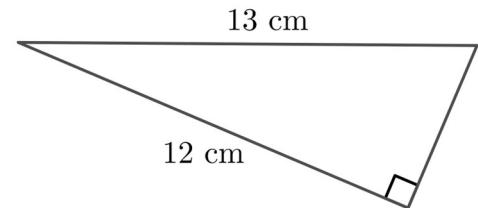

7) For each of the following, the side lengths of a triangle are given. Determine if the triangle is a right triangle.

a) 39 cm, 80 cm, 89 cm

b) 95 m, 263 m, 240 m

c) 140.5 ft, 80 ft, 115.5 ft

8) A rectangular park has a straight path from one corner to the opposite corner. If the park has dimensions of 2 km by 1.4 km, determine the length of the path.

9) A 12-foot ladder is leaned against the side of a building. If the bottom of the ladder rests 3 feet from the wall, determine the height at which the top of the ladder rests on the wall.

10) In the game of baseball, the distance from one base to the next is 90 feet, as shown in the diagram on the right. Determine the distance from home plate to second base.

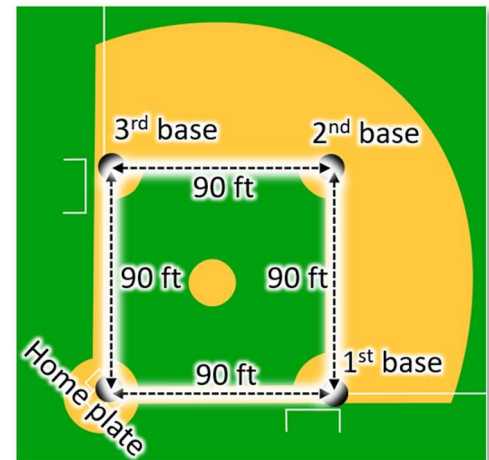

11) An inspector, equipped only with a tape measure, wants to determine if two walls were built at a 90° angle to each other. From the corner where the walls meet, he measures and marks 3 feet along one wall and 4 feet along the other. Explain how the inspector could now determine if the walls make a right angle.

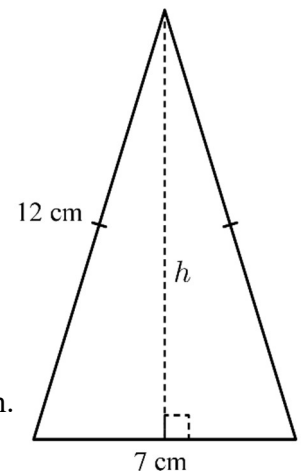

12) Determine the height, h , of the isosceles triangle shown on the right.

13) Determine the height of an equilateral triangle with side lengths of 14.5 cm.

14) Determine the perimeter and area of each figure.

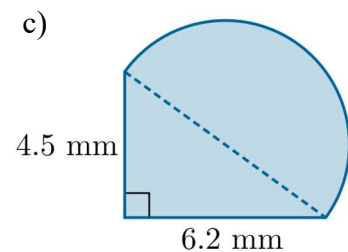
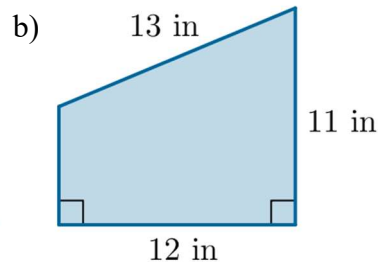
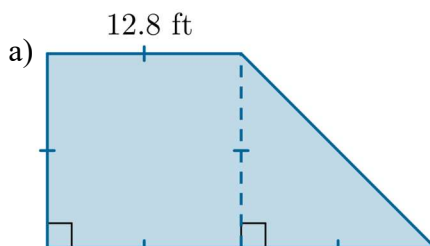

- 15) In the diagram on the right, a square is *inscribed* in a circle. If the square has a side length of 6 cm, determine the area of the shaded region.

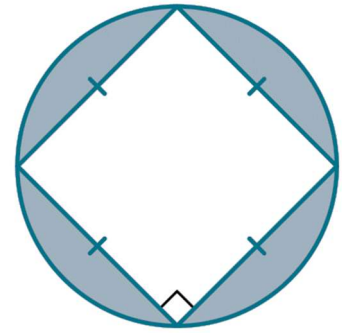

- 16) When a triangle is inscribed in a semicircle, a right angle is always formed at the point on the circular arc. Calculate the area of the shaded region in the diagram below.

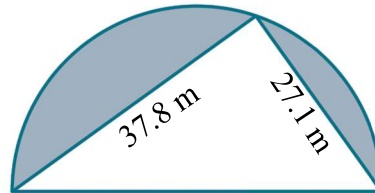

PART C

- 17) Determine the perimeter of the triangle shown on the right.

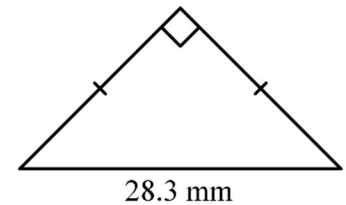

- 18) A television screen has a width-to-height ratio of 16:9. If the diagonal of the screen is 65 inches, determine its width and height.

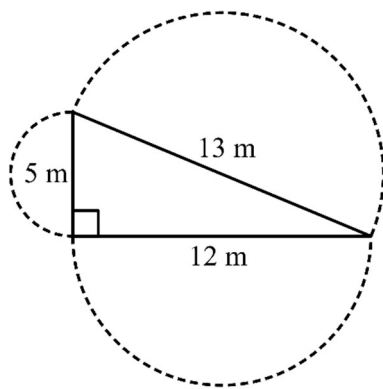

- 19) Did you know that the area relationship in the Pythagorean Theorem holds true for shapes other than squares? For example, show that the sum of the two smaller semicircles add up to the area of the hypotenuse semicircle in the diagram on the left.

- 20) Determine the length of the diagonal, d , for the rectangular prism shown on the right.

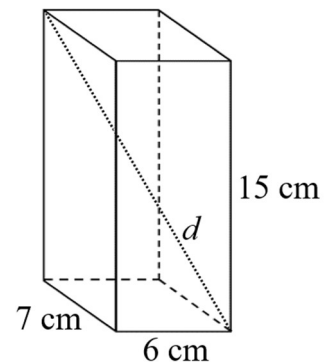

- 21) Pamela recently purchased a tall shelf for her bedroom closet. She wants to assemble the outer frame with it resting on its front/back, but she's concerned that it will hit the ceiling when she tilts it up into its standing position (see diagram on the right). In its upright position, *the frame has a height of 236 cm. Its base is a square with side lengths of 58 cm. If the ceiling is 244 cm high, will Pamela have enough clearance to stand the constructed frame? If so, by how much will it clear the ceiling?*

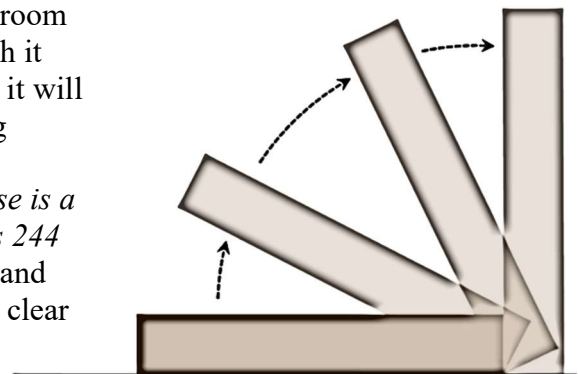

ANSWERS

- 1) a) c b) e c) x d) r
- 2) a) 169 m^2 b) 64 cm^2
- 3) a) $a = 9 \text{ cm}, b = 12 \text{ cm}, c = 15 \text{ cm}$ b) $a \approx 9.6 \text{ m}, b \approx 18.1 \text{ m}, c \approx 20.5 \text{ m}$
- 4) 26 m
- 5) a) 13 cm b) 13.0 ft c) 7 m d) 7.4 cm
- 6) area = 30 cm^2 , perimeter = 30 cm
- 7) a) right triangle b) not a right triangle c) right triangle
- 8) 2.4 km
- 9) 11.6 ft
- 10) 127.3 ft
- 11) A right triangle with legs of 3 ft and 4 ft has a hypotenuse of 5 ft . The inspector can measure the distance from the 3 -foot mark on the one wall directly to the 4 -foot mark on the other wall. If this distance is 5 ft , the walls make a 90° angle with each other. If this distance is not 5 ft , the walls do not make a 90° angle with each other.
- 12) 11.5 cm
- 13) 12.6 cm
- 14) a) perimeter $\approx 69.3 \text{ ft}$, area = 245.76 ft^2 b) perimeter = 42 in , area = 102 in^2
c) perimeter $\approx 22.7 \text{ mm}$, area $\approx 37.0 \text{ mm}^2$
- 15) 20.5 cm^2
- 16) 337.3 m^2
- 17) 68.3 mm
- 18) width = 56.7 in , height = 31.9 in
- 19) The hypotenuse semicircle has an area of approximately 66.4 m^2 , which is equal to the sum of the two smaller semicircles.
- 20) 17.6 cm
- 21) While being tilted into its standing position, the maximum height reached by the shelf will be the length of the diagonal along its side. This diagonal is approximately 243 cm long. Therefore, while being stood up, the shelf will clear the ceiling by approximately 1 cm .